



OPERATING AND MAINTENANCE INSTRUCTIONS
FOR CONSTANT CURRENT RECTIFIERS USING
SATURABLE CORE REACTORS

I. WARNING

Operating personnel should observe the following before attempting to operate or adjust the rectifier:

1. Do not tamper with AC power supply terminals of AC circuit within the rectifier unless the AC power, external to the unit, is turned "OFF". Contact with this high voltage can produce sever or fatal shock.
2. Do not exceed AC or DC ratings of the rectifier. Operating the rectifier at higher than nameplate ratings will result in eventual failure of the rectifier.
3. If overload protection trips repeatedly, investigate and eliminate cause before attempting further operation of rectifier.
4. If rectifier components overheat, or there is any evidence of electrical failure, turn rectifier "OFF" immediately. Do not attempt to operate rectifier until proper inspection and repairs have been completed.
5. The positive DC output terminals should always be connected to the anodes. NEVER connect this positive DC terminal to the structure to be protected, as irreparable damage will occur to the structure.
6. Return instruction manual and wiring diagrams to pocket provided on the inside of door. Do not place in bottom of rectifier and allow ventilation to be restricted.
7. Oil immersed rectifiers must have the oil level maintained at the specified level for proper cooling of components and also to meet rigid requirements for Class 1, Group D hazardous areas.
8. For three phase units, all similar (coarse or fine) voltage tap settings MUST be on the same "step" in all phases before AC power is turned "ON". Operating the rectifier with destroy the transformer.
9. Return instruction manual and wiring diagrams to pocket provided on the inside of door. Do not place in bottom of rectifier and allow ventilation to be restricted.

II. ROUTINE CHECKS PRIOR TO OPERATION

Your Universal Rectifier was fully inspected, carefully tested and was in top operating condition at the time of shipment. Instances where damage has resulted in shipping, handling, storage or installation are rare but possible. As a result, the following routine checks of your Universal Rectifier as well as the external AC and DC circuits are recommended:

1. **VISUAL INSPECTION.** Inspect unit for possible damage that may have resulted in shipping, handling or installation. If damage exists, do not attempt operation of rectifier until repairs have been complete.
2. **AC POWER SUPPLY.** Check phase and voltage of AC power supply. These should correspond to AC ratings of the unit, which is stamped on the nameplate.
3. **DC CIRCUITS.** Zero the DC meters. External DC load should be in proper operating condition. Connect ground bed (anodes) to positive (+) DC output terminal. Connect structure to be protected to negative (-) DC output terminals.
4. **CONNECTIONS.** Make sure all connections to and in your Universal Rectifier are tight. Where Universal voltage tap changer is used, voltage tap adjusting knobs need only be hand tight.

III. TO PLACE YOUR UNIVERSAL RECTIFIER IN OPERATION:

When in operation, the actual DC voltage and current output of the Universal Rectifier are indicated by the voltmeter and ammeter on the instrument panel of the rectifier. Care should be taken that these meter readings do not exceed either the DC voltage or DC current ratings of the unit. If ratings are exceeded, simply turn the corresponding current adjust potentiometer counter clockwise until unit is operating in designed limits.

1. Turn all current adjust potentiometers to lowest setting (counter clockwise).
2. Turn external AC power supply "ON".
3. Close circuit breaker or safety switch of rectifier ("ON" position).
4. Check DC ammeter and voltage readings on instrument panel.

IV. TO ADJUST DC CURRENT:

The following steps should be followed in sequence observing precautions in steps I, II and III until desired DC current is attained.

1. With the link bars or switch in the “HI” position, increase output current adjust knob clockwise till desired current is obtained.

Note: Only use the “LO” position of the link bar or switch to obtain extremely low current readings.

VI. GENERAL MAINTENANCE INSTRUCTIONS

1. Voltage, current and ambient temperature ratings of unit should not be exceeded.
2. Routine cleanliness should be maintained.
3. Adequate ventilation must be provided - screened openings should be kept free of obstructions.
4. All electrical connections should be tight.
5. Severe overloads can permanently damage rectifiers and special precautions may be required for abnormal or persistent overload exposures.
6. For oil immersed units, oil should be inspected periodically. Oil should be replaced when contaminated.

VII. MAINTAINING DESIRED CURRENT AND VOLTAGE

The rectifier unit will respond to electrical changes in the system external to the unit. Such as pronounced fluctuation of the AC line voltage or changes in ground bed resistance. Such changes can alter the operating DC voltage and/or current output of the rectifier. Periodic inspections should be made to assure desired operation and prevent any overloading. Voltage adjustments should be made as required. A permanent record of the current and voltage readings should be maintained. Any pronounced change that is not attributable to current adjustment should be investigated.

VIII. TROUBLE SHOOTING HINTS

A wiring diagram for use by experienced personnel is provided. Only experienced electrical personnel should attempt location and repair of electrical difficulties, should they occur. Some symptoms of elementary trouble and the possible remedy are as follows:

1. NO DC CURRENT OR DC VOLTAGE OUTPUT ON JUST ONE ZONE.

CHECK: Fuse on Auto board

2. NO DC CURRENT OR DC VOLTAGE OUTPUT ON ANY ZONE.

CHECK: AC overload protection for blown fuses (located behind main panel) or tripped circuit breaker. Check AC power supply.

3. DC VOLTAGE BUT NO DC CURRENT READING.

CHECK: DC ammeter. Check DC connections and external DC circuit for electrical continuity.

4. DC CURRENT READING BUT NO DC VOLTAGE READING.

CHECK: Check DC voltmeter

5. MAXIMUM RATED DC VOLTAGE CANNOT BE ATTAINED.

CHECK: Check AC line voltage. Check current adjustment settings for maximum. Check accuracy of DC voltmeter.

6. MAXIMUM RATED DC CURRENT CANNOT BE OBTAINED AT MAXIMUM DC VOLTAGE.

CHECK: Check load resistance of external DC circuit. Check accuracy of DC ammeter.

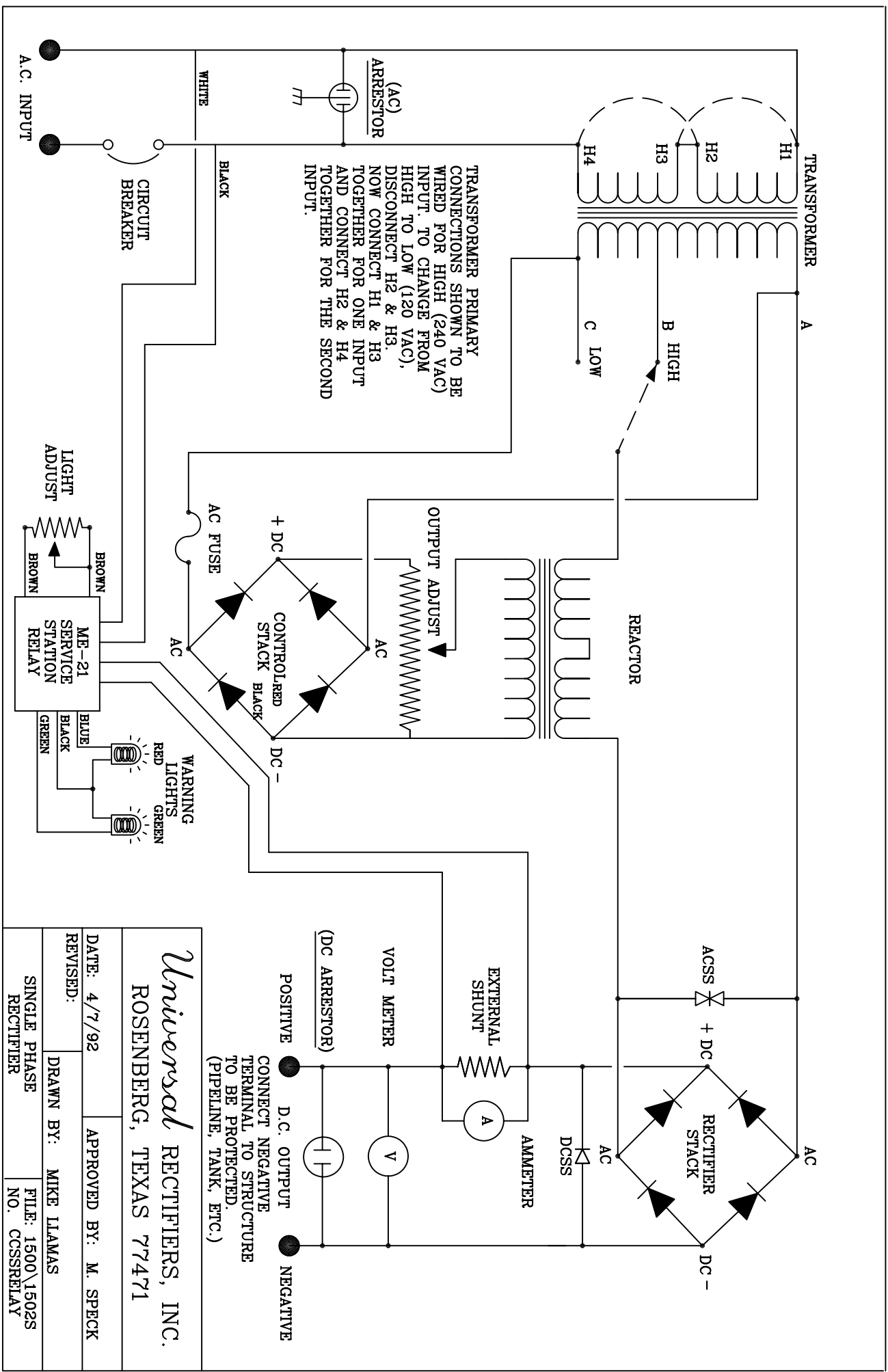

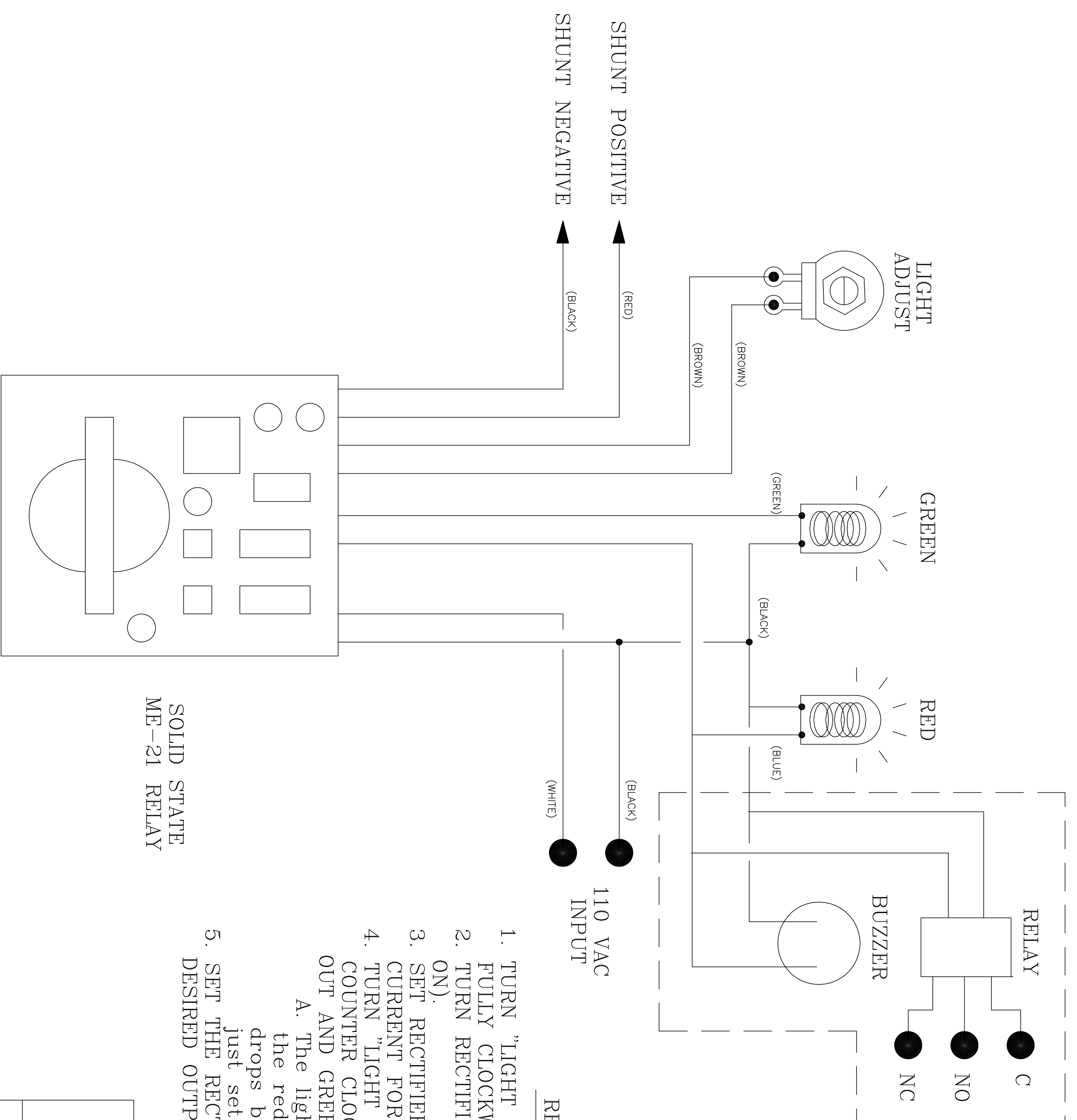

RELAY SETUP

1. TURN "LIGHT ADJUST" POTENTIOMETER FULLY CLOCKWISE.
2. TURN RECTIFIER "ON", (RED LIGHT SHOULD BE ON).
3. SET RECTIFIER OUTPUT TO DESIRED MINIMUM CURRENT FOR PROTECTION.
4. TURN "LIGHT ADJUST" POTENTIOMETER COUNTER CLOCKWISE SLOWLY UNTIL RED LIGHT JUST GOES OUT AND GREEN LIGHT JUST COMES ON.
 - A. The light is now set to turn the red light on if the rectifier current drops below the value that was just set.
5. SET THE RECTIFIER OUTPUT UP TO DESIRED OUTPUT.

Universal RECTIFIERS, INC.
ROSENBERG, TEXAS 77471

DATE: 6-12-97

APPROVED BY: M. SPECK

SCALE: N.T.S.

DRAWN BY: MIKE LIAMAS

SOLID STATE RELAY
ME-21 W/ GREEN LIGHT

FILE: \ACAD\RELAYS
NO. SSRELAY-WAC